

**Kinematics of Machines Paper - II**

P. Pages : 4

Time : Three Hours



**KNT/KW/16/7228/7253**

Max. Marks : 80

- Notes :
1. All questions carry marks as indicated.
  2. Solve Question 1 OR Questions No. 2.
  3. Solve Question 3 OR Questions No. 4.
  4. Solve Question 5 OR Questions No. 6.
  5. Solve Question 7 OR Questions No. 8.
  6. Solve Question 9 OR Questions No. 10.
  7. Solve Question 11 OR Questions No. 12.
  8. Due credit will be given to neatness and adequate dimensions.
  9. Assume suitable data whenever necessary.
  10. Illustrate your answers whenever necessary with the help of neat sketches.
  11. Use of non programmable calculator is permitted.
  12. Use drawing sheets, Retain all construction lines.

**1. Solve any seven**

**7x2**

- i) Define machine. Give at least four examples of different machines.
- ii) Define kinematic link. Identify & name the different links of slider crank mechanism.
- iii) What is pair variable? Identify the pair variables of (i) Turning pair (ii) Cylindric pair.
- iv) Define mechanism. Give two examples. How mechanism is different from structure?
- v) Draw neat sketch of class I four bar chain. Why it is class I (Note assume your own dimensions)
- vi) Three links are required to form a mechanism. True or False? Explain.
- vii) Define Inversion. What are the inversions of double slider crank chain?
- viii) Draw neat sketch of any six link mechanism with one DOF.
- ix) What is intermittent motion. Give at least two examples of intermittent motion mechanisms with applications.

- 2.**
- i) Draw neat sketch of Crank slotted lever quick return mechanism. Prove that it is an inversion of single slider crank chain. Crank length – 100 mm distance between two pivots – 300 mm (connecting rod)

**6**

ii) For the figures shown determine mobility.

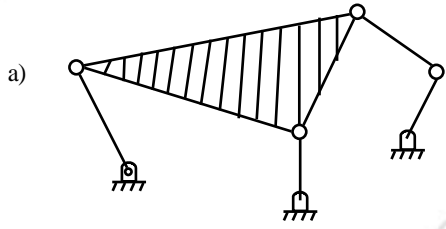

a)

2

Fig. a

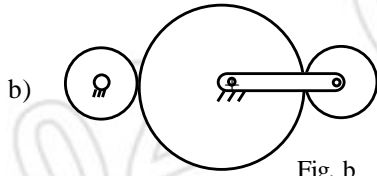

b)

2

Fig. b

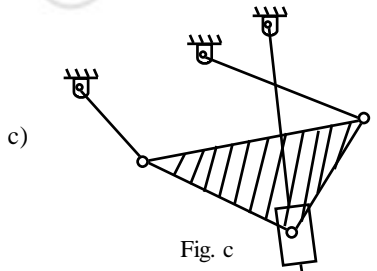

c)

2

Fig. c

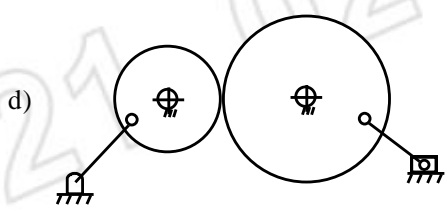

d)

2

Fig. d

3. For the mechanism shown determine graphically the displacement of point C if Crank is rotated through 360°.

13

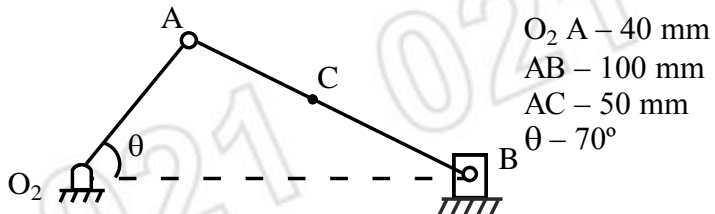

Fig. 3 (a)

Also determine the velocity & acceleration of point C when Crank is rotatory at 20 w/s at  $\theta = 70^\circ$ .

4. a) What is Coriolis component of acceleration? Derive the relation for its magnitude. How its direction is obtained?

4

- b) State and prove Kennedy's theorem. For the figure shown locate all the instantaneous centres and determine velocity of link  $O_4B$  at  $O_2A$  rotates with 300 rpm. 9

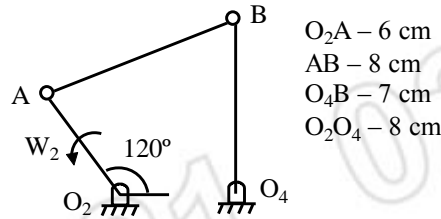

Fig. 4 (a)

5. a) What are the advantages of Cam follower mechanism over linkages? Give at least two examples of machines in which Cams are used for motion transmission. 4
- b) What is pressure angle in Cams? What is its role in cam design? What is pitch point? 4
- c) Draw displacement, velocity and acceleration diagram for the motion program of a Cam given below. Locate max velocity and acceleration points on the diagrams. 6
- |            |   |             |
|------------|---|-------------|
| Motion     | → | SHM         |
| Rise angle | → | $120^\circ$ |
| dwell      | → | $30^\circ$  |
| Rise       | → | 50 mm       |

Assume angular velocity 1rad/s .

6. Draw the Cam profile of a radial Cam with a roller reciprocating follower of radius 10 mm and a lift of 40 mm. Minimum Cam radius is 40 mm and it rotates at 600 rpm anticlockwise. The rise is cycloidal for  $120^\circ$  of the Cam rotation, dwells for next  $30^\circ$  and then lowers with parabolic motion for the next  $150^\circ$ , dwells for rest of the motion. Determine the magnitude of acceleration during rise. 14
7. a) State law of conjugate gear tooth action. Explain how involute profile satisfies law of gearing. 4
- b) Define module. What is its significance in gears? 2
- c) For a pair of rack and pinion derive relation for minimum number of teeth on pinion. 4
- d) Differentiate between helical gear and spur gear (at least four). 3
8. a) Two  $20^\circ$  involute spur gears have a module of 6 mm. The larger wheel has 40 teeth and the pinion has 20 teeth. If the addendum be equal to one module, will the interference occur? What will be the effect of the number of teeth on the pinion is reduced to 14. 4
- b) For the gear train shown determine the speed of Annular<sup>(D)</sup> of the sun of 40 teeth is driven by an external gear<sup>(A)</sup> of 20 teeth with 400 rpm clockwise as shown in fig. The sun<sup>(B)</sup> drives pinion<sup>(C)</sup> of 16 teeth held by an arm. The arm rotates at 100 rpm counterclockwise. Determine the number of teeth on gear D. 9

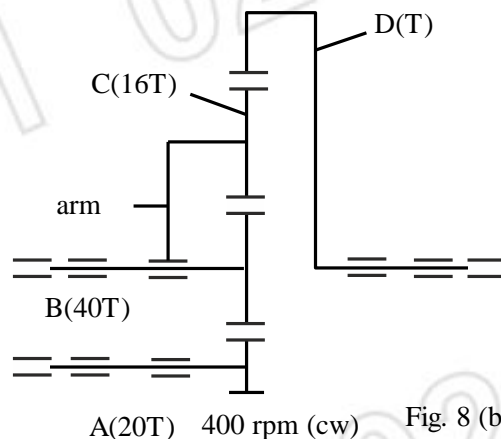
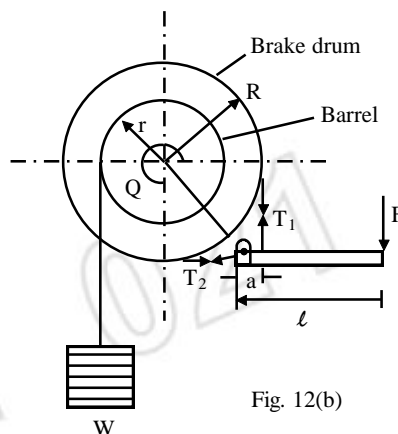

Fig. 8 (b)

9. a) Design a single slider crank mechanism for a stroke of 100 mm and crank to connecting rod ratio of 0.25. Draw neat sketch of the mechanism when the crank is at 230°. **5**
- b) Derive Freudenstein's equation for the design of four bar mechanism. **8**
10. a) Design a Crank rocker mechanism for the following requirements : **8**
- Rocker length 100 mm.
  - Angle of Rocking 90°
  - Quick return ratio 1.2
- b) What is transmission angle? What is its role in mechanism design? For the problem 10 a find the values of maximum and minimum transmission angles and write your comments on the values. **5**
11. a) What is friction circle. **3**
- b) Prove  $\tan \phi = \mu$  where  $\phi$  is limiting angle of friction &  $\mu$  in coefficient of friction. **4**
- c) What are different types of dynamometer? Explain the working of Rope Brake dynamometer. **6**
12. a) A multiple disc clutch has 6 active friction surfaces. The power transmitted is 20kw at 400 rpm. Inner and outer radii of the friction surfaces are 90 and 120 mm respectively. Assuming uniform wear with a coefficient of friction 0.3, find the maximum axial intensity of pressure between the discs. **6**
- b) A crane is used to support a load of 1.1 tonne on the rope round its barrel of 360 mm diameter. The brake drum diameter is 560 mm, the angle of contact is 300° and the coefficient of friction between the band and the drum is 0.22. What will be the force  $f$  required at the end & the lever. Take  $a = 150$  mm,  $L = 800$  mm. **7**



\*\*\*\*\*